

# MODUSAT SINGLE PLATE COOLING INTERFACE UNIT (MSPC)

*Installation & maintenance instructions (These instructions must be read in conjunction with the ModuSat TP Installation & Maintenance manual 2551390)*

## ModuSat SP Cooling Typical Circuit Diagram

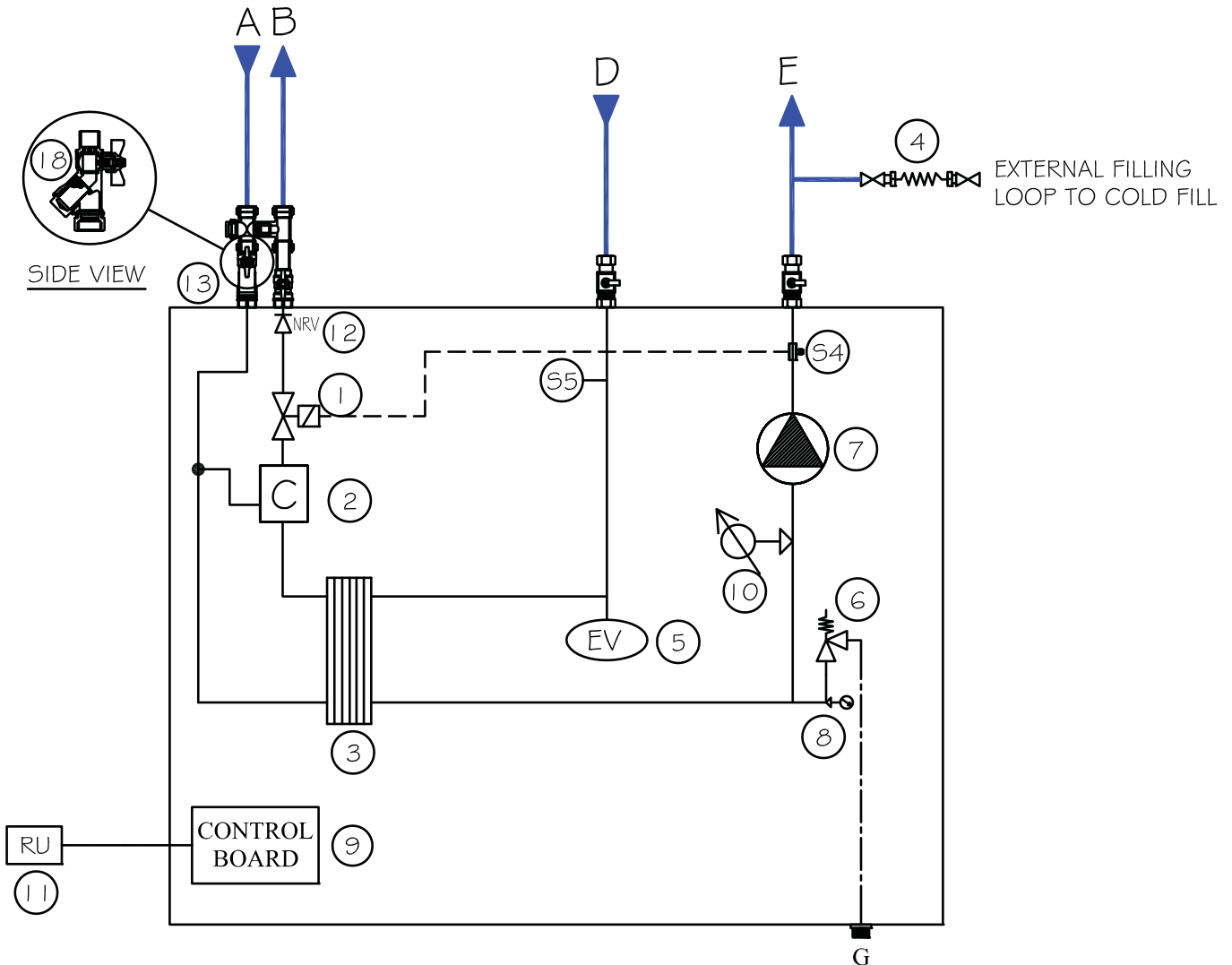

### Components

- |  |  |  |
|--|--|--|
| <p>A Primary circuit flow</p> <p>B Primary circuit return</p> <p>D Apartment circuit return</p> <p>E Apartment circuit flow</p> <p>G Connection for safety discharge</p> | <p>1 Pressure independent control valve (PICV) with actuator</p> <p>2 Ultrasonic energy meter</p> <p>3 Plate heat exchanger</p> <p>5 Expansion vessel</p> <p>6 Safety relief valve</p> <p>7 Circulation pump</p> | <p>8 Manometer</p> <p>9 Electronic control board</p> <p>10 LP switch</p> <p>11 Room control unit</p> <p>12 Non return valve</p> <p>13 Strainer &amp; IV assembly</p> |
|--|--|--|

# ModuSat SP Typical Dimensions

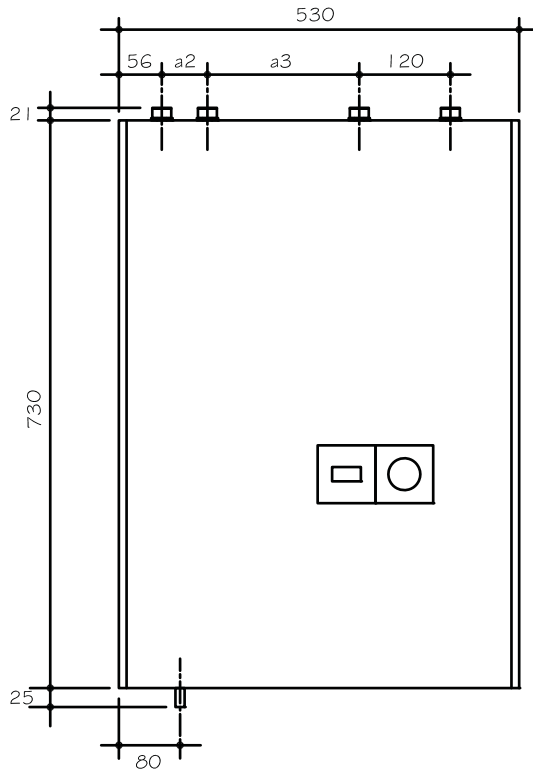

FRONT VIEW

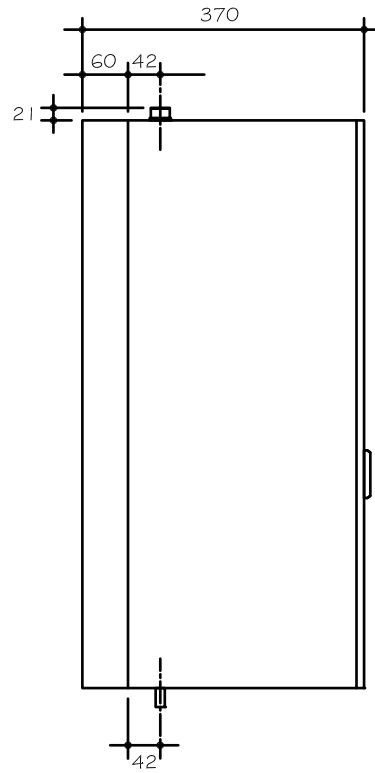

SIDE VIEW

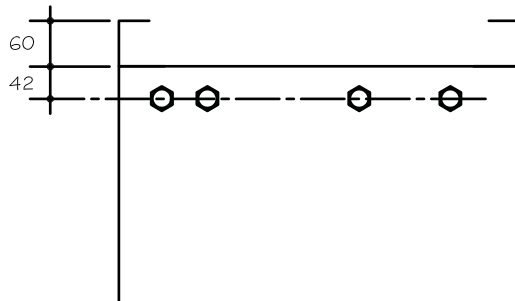

PLAN VIEW

CONNECTION Ø	a2	a3
22mm	60mm	200mm
28mm	90mm	170mm

***(Installation & maintenance instructions - These instructions must be read in conjunction with the ModuSat TP Installation & Maintenance manual 2551390)***

The MSPC (ModuSat Single Plate Cooling) is very similar to that of the MTP although this model features a single plate sized for cooling.

The procedure for installation and commissioning of the single plate unit is fundamentally the same as the MTP unit and therefore this document should be read in conjunction with the ModuSat TP Installation & Maintenance Manual 2551390.

- Specific attention is directed to the required electrical connections in section 5.
- Details of water treatment, system cleanliness and operation of the flushing bypass included with the valve kits are detailed within section 4.
- Initial commissioning and system balancing should be carried out as described in section 6.1 and 6.2.
- The ModuSat SPC unit features a wall spacer this is to accommodate the extra space required for the pipe lagging and flushing bypass lever. Please follow the pre-installation rig & wall fixing instructions as detailed in sections 3.5 & 3.6.
- The use of the internal commissioning switch is as detailed in section 6.3.
- The PWM pump operation and led status indicators are as per section 6.5.
- All warranties / guarantees are as section 6.6 in the MTP install manual.

**Pressure Independent Control Valve (PICV) Adjustment**

As the MSPC features a single plate heat exchanger only one PICV is installed for energy control, balancing and DPC. The plate heat exchanger and PICV are sized according to the project requirements. To identify the PICV model in the SP unit please refer to the dial on the PICV, as shown in the picture below –

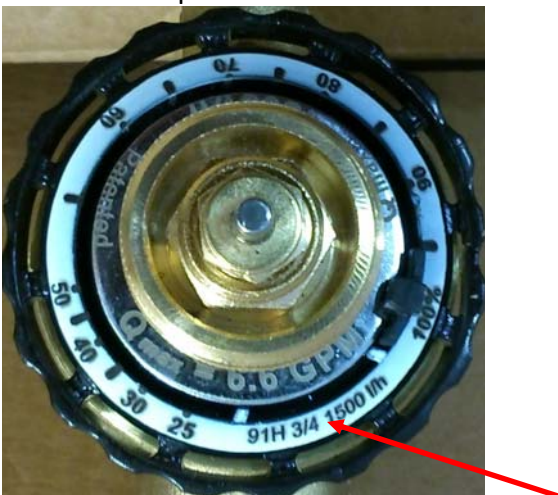

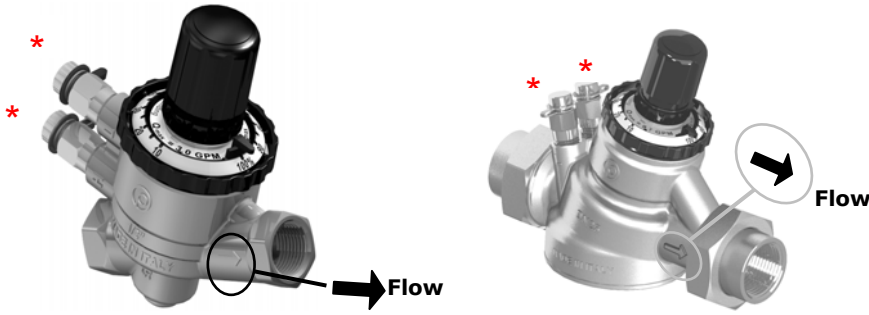

The PICV contained within the ModuSat is a combined flow regulation, DP control and energy valve. The valve will be pre-set during commissioning based on the design parameters, however adjustment can be to the Qmax (Maximum flow) if required.

### PICV Technical Data

TECHNICAL DATA	91L ¾"	91H ¾"	93L ¾" – 1"	93H ¾" – 1"	93L 1.¼"	93H 1.¼"
Max flow rate	1000 l/h 0.278 l/s	1500 l/h 0.417 l/s	2200 l/h - 0.611 l/s	2700 l/h - 0.750 l/s	2700 l/h - 0.750 l/s	3000 l/h - 0,833 l/s
Max. Flow accuracy [Δp 0.3 ÷ 1 bar]	±5%	±10%	±5%	±5%	±5%	±5%
Start-up Δp → Q=const.	25 kPa 0.25 bar	35 kPa 0.35 bar	25 kPa – 0.25 bar	25 kPa – 0.25 bar	25 kPa – 0.25 bar	25 kPa – 0.25 bar
Max Δp	400 kPa – 4 bar	400 kPa – 4 bar	400 kPa – 4 bar	400 kPa – 4 bar	400 kPa – 4 bar	400 kPa – 4 bar
Temperature	-10 ÷ 120 °C	-10 ÷ 120 °C	-10 ÷ 120 °C	-10 ÷ 120 °C	-10 ÷ 120 °C	-10 ÷ 120 °C
Max working pressure	2500 kPa 25 bar	2500 kPa 25 bar	2500 kPa – 25 bar	2500 kPa – 25 bar	2500 kPa – 25 bar	2500 kPa – 25 bar
Connections	Rp ¾" F EN10226-1	Rp ¾" F EN10226-1	Rc - EN10226-1	Rc - EN10226-1	Rc - EN10226-1	Rc - EN10226-1

### MANUAL ADJUSTMENT OF THE QMAX (MAXIMUM PRIMARY FLOW)



Carefully Lift up locking device

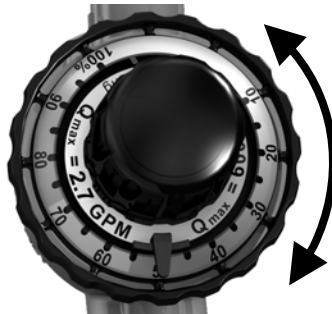

Select the flow rate by rotating the pre-setting ring



Carefully Push down locking device

PRE-SETTING %	91L ¾"		91H ¾"		93L ¾" – 1"	
	Flow l/h	Flow l/s	Flow l/h	Flow l/s	Flow l/h	Flow l/s
100%	1000	0.278	1500	0.417	2200	0.611
90%	900	0.250	1350	0.375	1980	0.550
80%	800	0.222	1200	0.333	1760	0.489
70%	700	0.194	1050	0.292	1540	0.428
60%	600	0.167	900	0.250	1320	0.367
50%	500	0.139	750	0.208	1100	0.306
40%	400	0.111	600	0.167	880	0.244
30%	300	0.083	450	0.125	660	0.183
20%	200	0.056	-	-	440	0.122
10%	100	0.028	-	-	220	0.061

PRE-SETTING %	93H ¾" – 1"		93L 1.¼"		93H 1.¼"	
	Flow l/h	Flow l/s	Flow l/h	Flow l/s	Flow l/h	Flow l/s
100%	2700	0.750	2700	0.750	3000	0.833
90%	2430	0.675	2430	0.675	2700	0.750
80%	2160	0.600	2160	0.600	2400	0.667
70%	1890	0.525	1890	0.525	2100	0.583
60%	1620	0.450	1620	0.450	1800	0.500
50%	1350	0.375	1350	0.375	1500	0.417
40%	1080	0.300	1080	0.300	1200	0.333
30%	810	0.225	810	0.225	900	0.250
20%	540	0.150	540	0.150	600	0.167
10%	270	0.075	270	0.075	300	0.083



**FOR THE CORRECT USE OF THIS PRODUCT, WATER QUALITY MUST BE HIGH AND COMPLY WITH CURRENT BSRIA & CIBSE GUIDELINES AND EVINOX REQUIREMENTS.**

Please note that the flow rates stated are subject to a + / - 5% tolerance.

#### TYPICAL ACTUATOR FITTING / REMOVAL



Carefully remove the handwheel

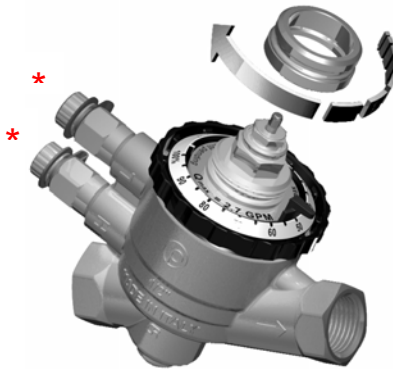

Screw the ring adaptor by hand

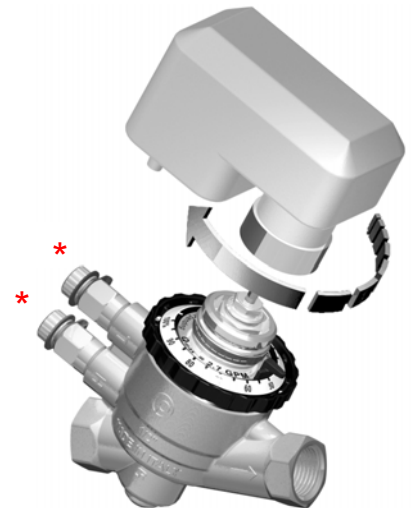

Screw the nut actuator by hand

The removal is the reverse of the above as the actuators are pre-fitted. Removal should only be carried out in the event of failure and following discussion and approval from an Evinox engineer.

In the event that the pressure parameters need to be checked during operation, temporary binder points can be installed for testing purposes by an Evinox engineer to ensure they are within the max / min tolerance, the following data can be checked:-

**For 91L 3/4" & 91H 3/4"**

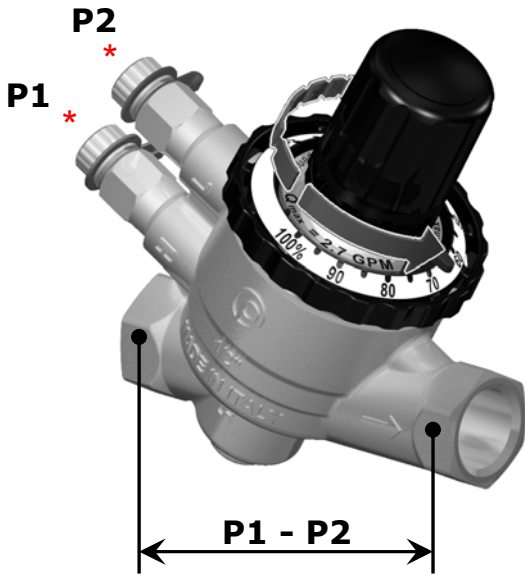

If  $P1-P2 > 20 \text{ kPa}$  THEN  
THE VALVE IS WITHIN THE WORKING RANGE

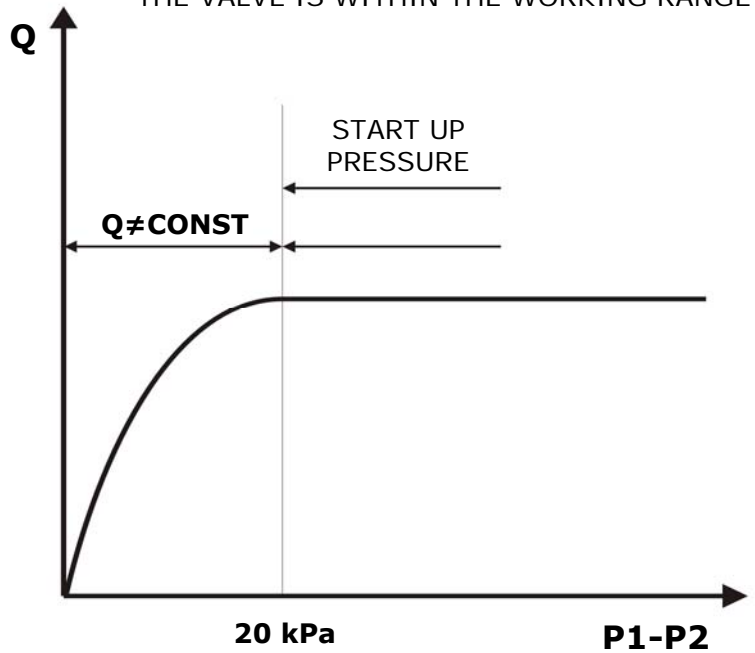

\* Please note that the binder points are not supplied with the valve as standard. Temporary binder points can be installed by an Evinox engineer should any checks be required.

**For 93L 3/4-1", 93H 3/4-1", 93L 1.1/4" & 93H 1.1/4"**

**P1 = H** pressure port  
**P2 = L** pressure port

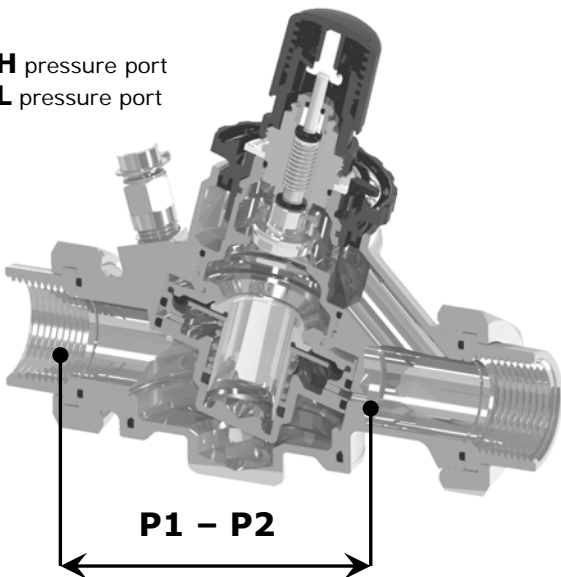

If  $P1-P2 > 25 \text{ kPa}$  THEN  
THE VALVE IS WITHIN THE WORKING RANGE

